

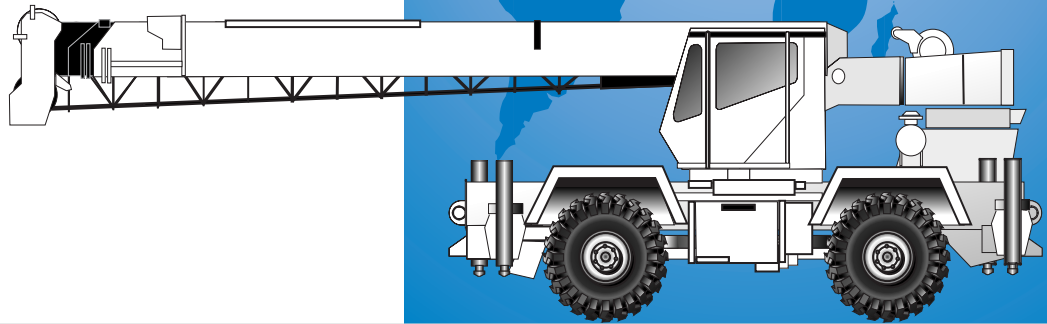

**GROVE.**  
**CRANE**

# RT528C



**Rough Terrain Crane**

**Grue Tout Terrain**



**Geländekran**

**Grúa Todo Terreno**

**METRIC**

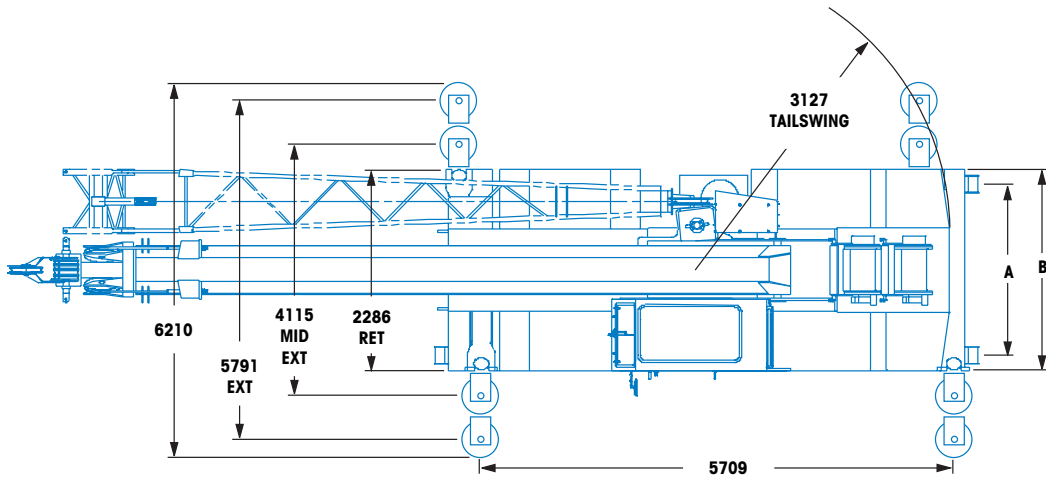
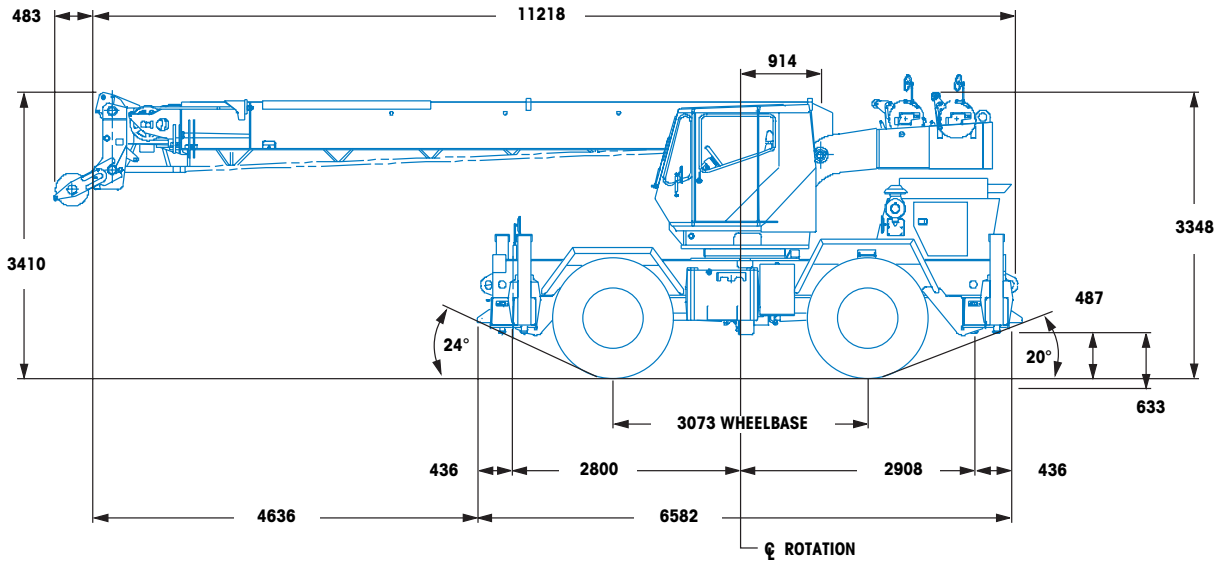
**Dimensions**  
**Abmessungen**  
**Encombrement**  
**Dimensiones**



	 16.00 x 25	 20.5 x 25
A	1969	2061
B	2438	2667
TURNING RADIUS / WENDERADIUS / RAYON DE BRAQUAGE / RADIO DE GIRO: 5182		

**Working range**  
**Arbeitsbereiche**  
**Portée flèche**  
**Gama de trabajo**



8.6 – 21.3 m



7.6 – 13.1 m



360°

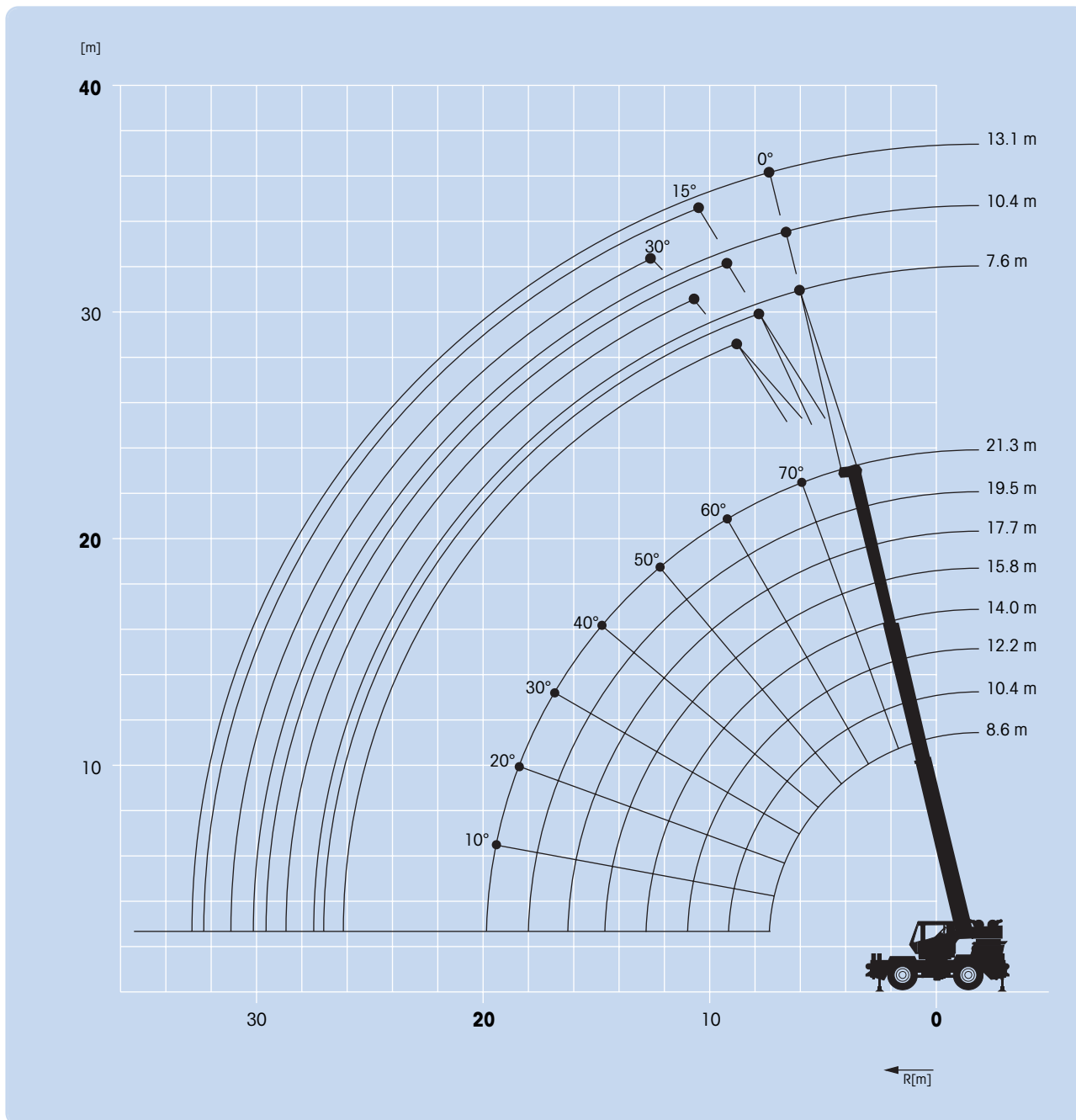

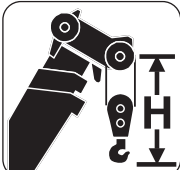
	Hook block • Unterflasche • Crochet-moufle • Gancho (t)	H (mm)
	<b>25</b>	<b>1371</b>
<b>10.9</b>	<b>1240</b>	
<b>4.5 H/B</b>	<b>787</b>	
—	—	

**Weights/Working speeds**  
**Gewichte/Geschwindigkeiten**  
**Poids/Vitesses**  
**Pesos/Velocidades de trabajo**



<b>Axle</b> <b>Achse</b> <b>Essieu</b> <b>Eje</b>	<b>1</b>	<b>2</b>	<b>Total weight</b> <b>Gesamtgewicht</b> <b>Poids total</b> <b>Peso total</b>
t	10.9	13.2	24.1



<b>Lifting Capacity</b> <b>Traglast</b> <b>Force de levage</b> <b>Capacidad de elevación</b>	<b>Sheaves</b> <b>Rollen</b> <b>Pulies</b> <b>Poleas</b>	<b>Parts of line</b> <b>Stränge</b> <b>Brins</b> <b>Ramales de cable</b>	<b>Weight</b> <b>Gewicht</b> <b>Poids</b> <b>Peso</b>
25 t	4	2 - 8	272 kg
10.9 t	1	1 - 3	163 kg
4.5 t	H/B	1	78 kg



+

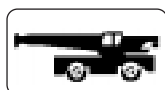

	<b>1 (F &amp; R)</b>	<b>2 (F &amp; R)</b>	<b>3 (F &amp; R)</b>	
km/h	10	21	37	
km/h	4	9	19	110.5%
	20.5 x 25			



+



	<b>Infinitely variable</b> <b>stufenlos</b> <b>progressivement variable</b> <b>Infinitamente variable</b>	<b>Rope</b> <b>Seil</b> <b>Câble</b> <b>Cable</b>	<b>Max. permissible line pull</b> <b>Maximal zulässige Seilzugkraft</b> <b>Effort maximum autorisé sur brin simple</b> <b>Potencia máxima admisible por ramal</b>
	0 - 131 m/min single line für einfachen Strang au brin simple ramal simple	16 mm/106 m	4119 kg
	0 - 131 m/min single line für einfachen Strang au brin simple ramal simple	16 mm/106 m	4119 kg
	0 - 2.5 min <sup>-1</sup>		
	0° to + 75° approx. 25 s ca. 25 s env. 25 s aproximadamente 25 s		
	8.6 m to 21.3 m approx. 47 s ca. 47 s env. 47 s aproximadamente 47 s		

# Superstructure specification

## Boom

8.6 m to 21.3 m three section full power boom.  
Maximum tip height 23.1 m.

## Boom elevation

2 cylinders with safety valves, boom angle from 0° to 75°.

## Load moment and anti-two block system

Load moment and anti-two block system with audio-visual warning and control lever lock-out. These systems provide electronic display of boom angle, length, radius, tip height, relative load moment, maximum permissible load, load indication and warning of impending two block condition.

## Cab

Galvanealed steel, acoustically treated, fixed skylight with manual wiper, deluxe seat with armrest-integrated crane controls. Ergonomically arranged instrumentation and crane operating controls. Drive/steer controls.

## Slewing

360° continuous rotation, planetary glide swing with foot applied brake. Spring applied hydraulically released parking brake and plunger type, 1 position mechanical house lock and 360° mechanical slew lock operated from cab.

## Counterweight

4,610 kg removable, or equivalent with \*auxiliary hoist fitted.

## Hydraulic system

3 main gear pumps combined capacity 426 l/min. Return line filter with by-pass protection. Remote mounted thermostatically controlled oil cooler and system pressure test panel. Tank capacity: 333 l.

## Control system

Stepless control of all crane movements using single axis hydraulic pilot control levers with automatic reset to zero.

## Hoist

Vane motor with planetary gear and automatic spring applied multi-disc brake. Grooved drum, hoist drum cable followers and electronic rotation indicator.

## \*Optional equipment

7.0 m A-frame jib (offsets 0°, 15°, 30°).  
7.6 m fixed non-offsettable lattice swingaway.  
7.6 - 13.1 m telescopic lattice swingaway (offsets 0°, 15°, 30°).  
Auxiliary boom nose.  
Auxiliary hoist.  
High Speed Glide System.  
Opening skylight with electric wiper.  
Diesel, propane or hydraulic oil cab heater.  
Air conditioning.  
Dual axis joystick control levers.  
LMI light bar.

# Carrier specification

## Carrier frame

Special 2-axle carrier, all-welded torsion-resistant box type construction in high strength steel. Integral towing and tie down lugs.

## Outriggers

4 hydraulically telescoping beams with 'inverted' jacks and 419 mm square outrigger pads. Independent horizontal and vertical movement control from the crane operator's cab. Three position setting. Sight level gauge. Maximum outrigger pad load: 22,795 kg.

## Engine

Cummins 6BT5.9L, 6 cylinder water cooled, turbocharged diesel. 97 kW (130 bhp) at 2500 rpm. Max. torque: 523 Nm at 1400 rpm. Fuel tank capacity: 227 l.  
Engine emission: EUROMOT / EPA / CARB (non road).

## Transmission

Clark powershift 18000 series, 6 forward and 6 reverse speeds.

## Drive/Steer

4 x 4 x 4

## Axles

2 axles driven and steered. Rear axle disconnect for 4 x 2 travel.

## Suspension

Front axle rigid mounted to frame. Rear axle pivot mounted. Automatic oscillation lockouts permit oscillation only with boom centred over front.

## Tyres

4 tyres, 20.5 x 25 - 24 PR earthmover type.

## Steering

Front, full hydraulic steering wheel controlled. Separate steering of the rear axle for rear, crab and coordinated steering.

## Brakes

Service brake: air over hydraulic dual circuit, acting on all wheels.  
Parking brake: spring-applied, air released front axle mounted.

## Electrical system

12 V (Two 12 V maintenance free batteries).

## \*Optional equipment.

4 tyres 16.00 x 25 - 28 PR (vehicle width 2.4 m).  
Ether cold start aid (less canister).  
Tachometer.  
Engine block heater.  
Pump disconnect with engine jogging switch.  
Differential locks (rear axle).  
Front mounted tow winch.  
Emergency steer pump.  
Air dryer.  
Tyre inflation kit.

\*Further optional equipment upon request

# Technische Daten: Kranoberwagen

## Teleskopausleger

8,6 m bis 21,3 m vollhydraulisch teleskopierbarer 3-Stufen-Ausleger.  
Maximale Rollenhöhe 23,1 m.

## Wippwerk

2 Hubzylinder mit Sicherheitsventilen, Auslegerwinkel 0° bis 75°.

## Lastmomentbegrenzer und Hubendabschaltesystem

Lastmomentbegrenzer und Hubendabschaltesystem mit audio-visueller Warneinrichtung und Bedienebelabschaltung. Diese Systeme bieten eine elektronische Anzeige von Auslegerwinkel, Auslegerlänge, Ausladung, Rollenhöhe, relative Last, maximal zulässige Last, tatsächliche Last sowie eine Hubende-Warneinrichtung.

## Kabine

Verzinkte, schallgedämmte Stahlkabine, starr eingebautes Dachfenster mit manuellem Scheibenwischer, Komfortsitz mit in die Armlehnen integrierten Bedienebeln, motorabhängige Heisswasserheizung. Ergonomisch angeordnete Bedienelemente und Kranbedienebel. Fahr- und Lenkbedienung.

## Drehwerk

360° rundum kontinuierlich schwenkbar, Planetenschwenkwerk mit Fusspedalschwenkbremse. Hydraulisch lösbare Federspeicher-Feststellbremse und mechanische, in 1 Stellung verriegelbare Bolzenverriegelung sowie von der Kabine aus bedienbare mechanische 360°-Schwenkwerkverriegelung.

## Gegengewicht

4610 Kg abnehmbar, oder entsprechendes Gegengewicht bei Ausstattung mit \*wahlweiser Hilfswinde.

## Hydrauliksystem

3 Hauptzahnradpumpen mit einer Gesamtfördermenge von 426 l/Min. Filter mit Vollstrom-Überströmventil im Rücklauf. Abgesetzt montierter, thermostatisch geregelter Ölkühler und Druckkontrollanschlüsse. Tankfassungsvermögen: 333 l.

## Steuerung

Stufenlose Bedienung aller Kranbewegungen mittels hydraulischer Einachs-Bedienebel mit automatischer Rückführung in die Nullstellung.

## Hubwerk

Lamellenmotor mit Planetengetriebe und automatischer Federspeicher-Lamellenbremse. Gerillte Seiltrommel, Windenseilführung und elektronische Umdrehungsanzeige.

## \* Zusatzausüstung

7,0 m A-Form-Klappspitze (abwinkelbar 0°, 15°, 30°).  
7,6 m starre, nicht abwinkelbare Gitterklappspitze.  
7,6 - 13,1 m Tele-Gitterklappspitze (abwinkelbar 0°, 15°, 30°).  
Hilfsrollenkopf.  
Hilfswinde.  
Auslegerdämpfungs-System.  
Aufklappbares Dachfenster mit elektrischem Scheibenwischer.  
Dieselöl-, Propangas- oder Hydrauliköl-Kabinenheizung.  
Klimaanlage.  
Zweiachs-Bedienebel.  
LMB (Lastmomentbegrenzer) Leuchtbalkenanzeige.

# Technische Daten: Kranunterwagen

## Rahmen

2-Achsen-Spezial-Unterwagenrahmen, vollverschweißte, verwindungsfeste Kastenprofil-Konstruktion aus hochfestem Stahl. Integrierte Schlepp- und Verstauesen.

## Abstützung

4 hydraulisch teleskopierbare Abstützbalken mit innengeführten Stützzyllindern und 419 mm quadratischen Abstützstellern. Unabhängige Bedienung der horizontalen und vertikalen Bewegungen von der Krankabine aus. Teil-Auslage in 3 Stellungen verbolzbar. Nivellierlibelle. Maximale Stütztellerlast: 22795 Kg.

## Motor

Cummins 6BTA5.9L, wassergekühlter 6-Zylinder-Turbodieselmotor mit Sekundärkühler. 97 KW (130 PS) bei 2500 U/Min. Max. Drehmoment: 523 Nm bei 1400 U/Min. Fassungsvermögen Treibstofftank: 227 l. Abgasemission: EUROMOT / EPA / CARB (nicht Strasse).

## Getriebe

Clarc Powershiftautomatikgetriebe Serie 18000, 6 Vorwärtsgänge und 6 Rückwärtsgänge.

## Antrieb/Lenkung

4 x 4 x 4

## Achsen

Zwei Achsen angetrieben und lenkbar. Hinterachse für 4 x 2 Fahrt abschaltbar.

## Federung

Vorderachse starr am Unterwagenrahmen montiert. Hinterachse als Pendelachse montiert. Die automatische Federungsverriegelung entriegelt die Federung nur dann, wenn der Ausleger nach vorn eingemittet ist.

## Bereifung

4 Reifen, 20.5 x 25 - 24 PR Radladerreifen.

## Lenkung

Vorn vollhydraulische Lenkung mittels Lenkrad. Separate Lenkung der Hinterachse für hintere Lenkung, Hundegang oder koordinierte Lenkung.

## Bremsen

Betriebsbremse: Druckluft/Hydraulik Zweikreis-Bremssystem, auf alle Räder wirkend.  
Feststellbremse: Pneumatisch lösbare Federspeicher-Feststellbremse, an der Vorderachse montiert.

## Elektrische Anlage

12 V (Zwei 12 V wartungsfreie Batterien).

## \* Zusatzausüstung

4 Reifen, 16.00 x 25 - 28 PR (Fahrzeugbreite 2,4 m).  
Äther-Kaltstarthilfe (Vergasereinspritzung).  
Drehzahlmesser.  
Motorblock-Heizung.  
Pumpenabschaltung mit Kurbelwellendreheschalter.  
Differentialsperren (Hinterachse).  
Frontmontierte Schleppwinde.  
Notlenkpumpe.  
Lufttrocknungsanlage.  
Reifenfüllanlage.

\*Weitere Zusatzausrüstungen auf Anfrage

# Caractéristiques de la superstructure

## Flèche

Flèche trois éléments de 8,6 m à 21,3 m à télescopage hydraulique.  
Hauteur max. de tête de flèche 23,1 m.

## Relevage

2 vérins avec clapet anti-retour, angle de flèche de 0° à + 75°.

## Contrôleur d'état de charge et dispositif de fin de course haute

Contrôleur d'état de charge et dispositif de fin de course haute avec alarme sonore et visuelle et dispositif de coupure des mouvements. Ces dispositifs électroniques affichent les indications d'angle et de longueur de flèche, de portée, de hauteur de tête de flèche, de moment relatif, de charge maximum admissible, de charge levée et d'approche de bloc à bloc.

## Cabine

Cabine en tôle galvanisée, insonorisée, avec baie de toit fixe et essuie glace manuel, siège capitonné avec commandes de grue montées sur les accoudoirs, instrumentation et commandes de grue disposées suivant études ergonomiques. Commandes de conduite pour le déplacement et la direction du porteur.

## Orientation

Orientation continue sur 360° avec réducteur à planétaires « glide swing » et frein au pied. Frein d'immobilisation à serrage par ressorts et desserrage hydraulique. Axe de verrouillage d'orientation en position route et dispositif de verrouillage mécanique 360° commandés depuis la cabine.

## Contrepoids

Contrepoids de 4.610 kg déposable ou équivalent avec \*treuil de levage auxiliaire installé.

## Circuit hydraulique

3 pompes principales à engrenages ayant un débit total de 426 l/min. Filtration sur circuit retour avec by-pass. Refroidisseur d'huile hydraulique à commande thermostatique monté à distance et panneau de prises de pressions centralisées. Capacité du réservoir : 333 l.

## Commandes de grue

Commandes progressives par leviers simple axe et retour au neutre automatique.

## Treuil

Moteur à palettes avec réducteur à planétaires et frein automatique à serrage par ressorts et desserrage automatique. Tambour de treuil rainuré, rouleau presse câble et indicateur électronique de rotation du tambour.

## \*Equipements optionnels

Extension en A de 7,0 m (inclinable à 0°, 15°, 30°).  
Extension treillis de 7,6 m, non télescopique, non inclinable.  
Extension treillis télescopique de 7,6 à 13,1 m (inclinable à 0°, 15°, 30°).  
Tête de flèche auxiliaire.  
Treuril auxiliaire.  
Amortisseur sur vérin de relevage pour déplacements en position route.  
Baie de toit ouvrante et essuie glace électrique.  
Chauffage de cabine au gazoil, au propane ou à l'huile hydraulique.  
Climatisation.  
Manipulateurs de commande « en croix ».  
Barre de répétition d'affichage de moment C.E.C.

# Caractéristiques du porteur

## Châssis porteur

Châssis caissonné, mécanosoudé, spécifique, 2 essieux, en tôles d'acier à haute limite élastique, avec oreilles de remorquage et d'arrimage intégrées.

## Calage

4 poutres à télescopage hydraulique avec vérins verticaux en position « inversée » et semelles d'appui carrées de 419 mm de côté. Commande indépendante des mouvements de sortie de poutres et de vérins depuis le poste de pilotage. Trois configurations de calage sont autorisées, 0 - 50 et 100%. Niveau à bulle. Charge maximum sur les appuis: 22.795 kg.

## Moteur

Moteur Diesel Cummins 6BT5.9L, 6 cylindres, à refroidissement liquide et dispositifs de suralimentation. 97 kW (130 CV) à 2500 tr/min. Couple max.: 523 Nm à 1400 tr/min. Capacité du réservoir de carburant : 227 l. Emissions de gaz polluants: EUROMOT / EPA CARB (normes chantier).

## Boîte de vitesses

Boîte de vitesses Clark 18000, 6 rapports de marche avant et 6 rapports de marche arrière.

## Direction/Déplacement

4 x 4 x 4

## Ponts

2 ponts moto-directeurs. Pont arrière débrayable pour déplacements sur route.

## Suspension

Pont avant rigide fixé au châssis. Pont arrière articulé. Le dispositif automatique de verrouillage d'articulation libère la suspension lorsque la flèche est centrée sur l'avant.

## Pneumatiques

4 pneumatiques 20.5 x 25 - 24 PR de type chantier.

## Direction

Direction avant hydraulique commandée par volant. Direction indépendante pour les roues arrière donnant les configurations : direction arrière, marche en crabe et direction coordonnée.

## Freins

Frein de service: double circuit pneumatique sur circuit hydraulique agissant sur toutes les roues. Frein de stationnement: à serrage par ressorts et desserrage pneumatique, monté sur essieu avant.

## Circuit électrique

12 V (Deux batteries 12 V sans entretien).

## \*Equipements optionnels

4 pneus 16.00 x 25 - 28 PR (largeur du véhicule 2,4 m).  
Dispositif d'aide au démarrage à froid (sans la recharge).  
Compte-tours.  
Réchauffage du bloc-moteur.  
Débrayage de pompe et commande de rotation du moteur.  
Blocage de différentiel (essieu arrière).  
Treuril de halage monté à l'avant.  
Pompe de direction de secours.  
Dessiccateur.  
Gonfleur autonome.

\*Autres équipements optionnels sur demande

# Especificación de la Superestructura

## Pluma

De 8,6 m. hasta 21,3 m en tres tramos de telescopaje totalmente hidráulico. Altura máxima en punta 23,1 m.

## Elevación de pluma

Dos cilindros con válvulas de seguridad. Angulo de pluma desde 0° hasta 75°.

## Sistema Indicador del Momento de Carga y de Final de Carrera del Gancho

Indicador del momento de carga y de final de carrera del gancho con alarma audiovisual y bloqueo automático de las palancas de control. Estos sistemas proporcionan información en la pantalla del ángulo de pluma, longitud, radios, altura, momento de carga relativo, carga máxima permitida, indicador de carga y alarma de final de carrera del gancho.

## Cabina

De acero galvanizado, tratada acústicamente, ventana superior fija con limpia manual, asiento de lujo con controles de operación de la grúa e instrumentación ergonómicamente situadas. Controles de traslación/dirección.

## Giro

Continuo a 360°, giro deslizante con planetarios y freno actuado por pedal. Freno de aparcamiento aplicado por muelle con desconexión hidráulica y pistón, bloqueo mecánico en 1 posición y bloqueo mecánico de giro en los 360° accionado desde la cabina.

## Contrapeso

Desmontable de 4.610 kg. o equivalente con \*cabrestante auxiliar montado.

## Sistema hidráulico

Tres bombas principales de engranaje con una capacidad combinada de 426 litros/minuto. Filtro en la línea de retorno con protección by-pass. Radiador de refrigeración de aceite con control por termostato y sistema de comprobación de presión en el panel. Capacidad del depósito 333 litros.

## Sistema de Control

Controles continuos de todos los movimientos de la grúa, usando palancas de control con retorno automático a cero.

## Cabrestante

Con motor de paletas, engranaje planetario y freno automático multidisco aplicado por muelle. Tambor acanalado, ordenador de cable en el tambor e indicador de dirección.

## \* Equipos Opcionales

Plumín de 7,0 m. tipo A (angulable 0°, 15° y 30°).

Plumín de 7,6 m. fijo de celosía, no angulable, plegable en un lateral de la pluma.

Plumín telescópico de 7,6-13,1 m., de celosía, plegable en un lateral de la pluma (angulable 0°, 15° y 30°)

Cabeza auxiliar de pluma, tipo nariz.

Cabrestante auxiliar.

Sistema de deslizamiento a alta velocidad.

Ventana superior con limpia eléctrico.

Calefacción en la cabina, diesel, propano o aceite hidráulico.

Aire acondicionado.

Palancas de control de doble eje.

Tubo de iluminación del Indicador de Cargas.

# Especificación del Chasis

## Bastidor

Chasis especial de dos ejes de construcción soldada tipo cajón resistente a la torsión, en acero de alta resistencia. Gancho de arrastre y orejetas de amarre.

## Estabilizadores

4 vigas telescópicas hidráulicas con cilindros verticales invertidos y placas de apoyo cuadradas de 419 mm. de superficie. Controles independientes para los movimientos horizontales y verticales desde la cabina del operador. Tres posiciones de aplicación. Manómetro indicador de nivel. Carga máxima en cada placa de apoyo 22.795 kg.

## Motor

Diesel Cummins 6BT5.9L, 6 cilindros, refrigerado por agua, turboalimentado, 97 Kw (130 bhp) a 2.500 rpm. Par máximo: 523 Nm a 1.400 rpm. Depósito de combustible: 227 litros. Emisión de gases: EUROMOT/EP/CARB (non-road).

## Transmisión

Clark powershift serie 18000, 6 velocidades adelante y 6 atrás.

## Tracción/Dirección

4 x 4 x 4

## Ejes

2 ejes motrices y directrices. Eje trasero desconectable para desplazamiento 4x2.

## Suspensión

Montaje rígido al bastidor en el eje delantero. En el eje trasero pivotante. Bloqueo automático de oscilación únicamente con la pluma centrada por la parte frontal.

## Neumáticos

4 de 20.5x25-24 lonas, tipo movimiento de tierras.

## Dirección

Delantera, completamente hidráulica con control por volante. Control independiente del eje trasero para dirección trasera, tipo cangrejo y coordinada.

## Frenos

De Servicio: Neumático sobre hidráulico de doble circuito, actuando sobre todas las ruedas.

De Aparcamiento: Aplicado por muelle con desconexión neumática sobre el eje delantero.

## Sistema eléctrico

12 V (dos baterías de 12 V sin mantenimiento).

## \* Equipos Opcionales

4 neumáticos de 16.00x25-28 lonas (anchura del vehículo 2,4 m.).

Sistema de ether para ayuda de arranque en frío (sin cesta).

Tacómetro.

Calentamiento del bloque motor.

Desconector de la bomba con el motor a baja velocidad mediante un interruptor.

Bloqueo del diferencial (eje trasero).

Cabrestante de arrastre en la parte delantera del chasis.

Bomba auxiliar de emergencia.

Secador de aire.

Juego para inflado de neumáticos.

\* Otros equipos opcionales a petición

# Notes referring to load charts

## Hinweise für Traglasttabellen

### Notes relatives aux tableaux des charges

### Notas para las tablas de cargas

#### Lifting capacities according to BS/DIN • 85%

**WARNING: THIS CHART IS ONLY A GUIDE. The Notes below are for illustration only and should not be relied upon to operate the crane.**

**The individual crane's load chart, operating instructions and other instruction plates must be read and understood prior to operating the crane.**

BS/DIN: Capacities are in accordance with DIN 15019: Part 2: 1979 and clause 9 - Stability of BS 1757: 1986.

85%: Capacities are in accordance with SAE J1063 and do not exceed 85% of the tipping load (75% for outriggers 0% extended) as determined by SAE J765.

Lifting capacities at 85% do **not** comply with the essential health and safety requirements of the EU Machinery Directive.

1. Capacities given do not include the weight of hookblocks, slings, auxiliary lifting equipment and load handling devices. Their weights **MUST** be added to the load to be lifted. When more than minimum required reeving is used, the additional rope weight shall be considered part of the load.
2. All capacities are for crane on firm, level surface. It may be necessary to have structural supports under the outrigger floats or tyres to spread the load to a larger bearing surface.
3. When either boom length or radius or both are between values listed, the smallest load shown at either the next larger radius or boom length shall be used.
4. For outrigger operation, ALL outriggers shall be fully extended with tyres raised free of ground before raising the boom or lifting loads.
5. Tyres shall be inflated to the recommended pressure before lifting on rubber.

#### Traglasten entsprechen BS/DIN • 85%

**WARNUNG: DIESE TABELLE IST LEDIGLICHE EINE RICHTLINIE. Die Hinweise dienen als Erklärung und sind für die Kranbedienung nicht maßgebend. Vor Inbetriebnahme des Kranes sind Traglasttabellen, Bedienungsanleitung und andere Vorschriften eingehend zu studieren.**

BS/DIN: Die Tragkraftwerte entsprechen DIN 15019 Teil 2, 1979 und der Klausel 9 - Stabilität von BS 1757, 1986.

85%: Tragkraftwerte entsprechen SAE J1063 und überschreiten nicht 85 % der Kipplast (75% bei ganz ausgefahrener Abstützung) gemäß Richtlinien SAE J 765.

Die 85% Traglasten entsprechen **nicht** den Sicherheitsanforderungen der EG-Maschinen-richtlinie.

1. Das Gewicht der Hakenflaschen und aller Anschlagmittel muß zu der Last hinzugerechnet werden. Beim Einscheren mit erhöhten Werten ist das zusätzliche Seilgewicht als Teil der Last zu betrachten.
2. Alle Werte gelten für den Kran auf festem, ebenem Untergrund. Eventuell müssen die Stützteller oder Reifen unterlegt werden, um die Last über eine größere Abstützfläche zu verteilen.
3. Wenn Auslegerlänge oder Radius oder beide Werte zwischen den aufgeführten Werten liegen, ist die geringere der Traglasten zu wählen, die für den die nächstgrößere Ausladung oder die nächste bzw. anschließende Auslegerlänge genannt sind.
4. In abgestütztem Zustand müssen ALLE Stützen komplette ausgefahren sein. Die Reifen dürfen den Boden nicht berühren. Erst danach dürfen Lasten oder der Ausleger angehoben werden.
5. Bevor frei auf Rädern gearbeitet wird, müssen, die Reifen mit dem vorschriftsmäßigen Druck aufgefüllt werden.

#### Capacités de levage selon BS/DIN • 85%

**ATTENTION: CE TABLEAU N'EST QU'UN GUIDE. Les notes ci-dessous sont données à titre d'exemple et ne devront pas être utilisées pour faire fonctionner la grue. Toute la documentation concernant chaque type de grue: tableau des charges, instructions de fonctionnement et toutes autres plaques d'instructions devront être lues et comprises avant de manoeuvrer la grue.**

BS/DIN: Les capacités de levage sont conformes à la norme DIN 15019 section 2 de 1979 et à la clause 9 - stabilité - de la norme BS1757: 1986.

85%: Les capacités de levage sont conformes à la norme SAE J1063 et ne dépassent pas 85% de la charge de basculement (75% pour les poutres de calage déployées à 0%) tel que cela est prescrit par la norme SAE J765. Les capacités de levage à 85% **ne** respectent pas les préconisations concernant la santé et la sécurité prévues par la Directive Machines CE.

1. Les charges mentionnées dans les tableaux ne comprennent pas le poids des moufles, des élingues et autres accessoires de levage qui doit être additionné à celui de la charge levée. Lorsque le mouflage est supérieur au minimum requis le poids de l'excédent de câble doit être additionné à celui de la charge.
2. Les capacités sont données sur sol ferme et de niveau. Il peut être nécessaire d'utiliser des bastaings ou des accessoires similaires afin de répartir la charge transmise au sol par les roues ou les patins de calage.
3. Lorsque la longueur de flèche ou la portée ne correspond pas aux valeurs mentionnées dans les tableaux, il convient de se référer à la valeur inférieure mentionnée pour la portée ou la longueur de flèche immédiatement supérieure.
4. Pour utilisation machine calée, les traverses de calage doivent être totalement télescopées et les roues décollées du sol avant de relever la flèche ou de lever des charges.
5. Les pneumatiques devront être gonflés aux pressions préconisées avant tout levage en libre.

#### Capacidades de elevación de acuerdo con BS/DIN • 85%

**AVISO: ESTA TABLA ES SOLO UNA ORIENTACION. Las notas que aparecen al final de la misma solo sirven de ilustración y no deben ser tomadas como instrucciones para operar la grúa. La tabla de cargas, las instrucciones de operación y otras placas ilustrativas de cada grúa deben ser leídas y correctamente interpretadas antes de operar la grúa.**

BS/DIN: Capacidades de acuerdo con las Normas DIN 15019: Apartado 2: 1979 y cláusula 9 - Estabilidad. BS1757: 1986.

85%: Capacidades de acuerdo con las Normas SAE J1063 y no exceden del 85% del momento de vuelco (75% para las cargas sobre estabilizadores extendidos al 0%) como fijan las normas SAE J765. Las capacidades de elevación al 85% **no** cumplen con las normas de seguridad exigidas por las Directivas de Maquinaria de la CEE.

1. Las cargas indicadas no incluyen el peso de los ganchos, eslingas, equipos auxiliares y aparos de elevación. Sus pesos **DEBEN** ser añadidos al de la carga a elevar. Cuando se utilice un número de ramales de cable superior al necesario, el peso adicional del cable debe ser considerado como parte de la carga.
2. Todas las capacidades corresponden a la grúa situada sobre terreno firme nivelado y uniforme. La naturaleza del terreno puede hacer necesario colocar, bajo los apoyos de los estabilizadores o bajo los neumáticos, elementos estructurales que repartan la carga sobre una mayor superficie de apoyo.
3. Cuando se trabaje con longitudes de pluma o rádios, intermedios entre los valores reflejados en las tablas, se considerará la carga inmediata inferior indicada en el radio o longitud de pluma inmediato superior.
4. Para trabajos sobre estabilizadores, **TODOS** los estabilizadores estarán totalmente extendidos y los neumáticos sin tocar el suelo antes de elevar pluma o izar cargas.
5. Los neumáticos deberán estar inflados a la presión recomendada antes de elevar cargas sobre neumáticos.

**Lifting capacities for telescopic boom**  
**Traglasten am Teleskopausleger**  
**Capacités de levage à la flèche télescopique**  
**Capacidades de elevación con pluma telescópico**



8.6 – 21.3 m



100%



360°



4,610 kg



**BS/DIN**

m	8.6	10.4	12.2	14.0	15.8	17.7	19.5	21.3
3.0	25,000	16,325	16,325					
3.5	18,140	16,325	16,325	15,875				
4.0	15,920	15,625	15,575	15,250				
4.5	14,285	14,250	14,200	13,900	13,500	13,225		
5.0	12,880	12,880	12,880	12,750	12,475	12,325		
6.0	10,700	10,700	10,700	10,700	10,600	10,425	10,100	9,295
7.0	9,025	9,025	9,025	9,025	9,025	8,985	8,750	8,480
8.0		7,845	7,845	7,845	7,845	7,845	7,780	7,575
9.0		7,095	7,095	7,095	7,095	6,985	6,890	6,810
10.0			6,350	6,350	6,350	6,235	6,165	6,075
12.0				4,700	4,700	4,700	4,705	4,705
14.0					3,520	3,520	3,525	3,525
16.0						2,695	2,700	2,700
18.0							2,100	2,100
20.0								1,635

A6-829-008853



**85%**

m	8.6	10.4	12.2	14.0	15.8	17.7	19.5	21.3
3.0	25,000	16,325	16,325					
3.5	18,140	16,325	16,325	15,875				
4.0	15,920	15,625	15,575	15,250				
4.5	14,285	14,250	14,200	13,900	13,500	13,225		
5.0	12,880	12,880	12,880	12,750	12,475	12,325		
6.0	10,700	10,700	10,700	10,700	10,600	10,425	10,100	9,295
7.0	9,025	9,025	9,025	9,025	9,025	8,985	8,750	8,480
8.0		7,845	7,845	7,845	7,845	7,845	7,780	7,575
9.0		7,095	7,095	7,095	7,095	6,985	6,890	6,810
10.0			6,350	6,350	6,350	6,235	6,165	6,075
12.0				4,985	4,985	4,985	4,985	4,965
14.0					3,940	3,940	3,940	3,940
16.0						3,065	3,065	3,065
18.0							2,425	2,425
20.0								1,935

A6-829-008641

**Lifting capacities for telescopic boom**  
**Traglasten am Teleskopausleger**  
**Capacités de levage à la flèche télescopique**  
**Capacidades de elevación con pluma telescópico**



8.6 – 21.3 m



50%



360°



4,610 kg



**BS/DIN**

m	8.6	10.4	12.2	14.0	15.8	17.7	19.5	21.3
3.0	22,500	16,325	16,325					
3.5	18,140	16,325	16,325	15,875				
4.0	15,920	15,625	15,575	15,250				
4.5	14,285	14,250	14,200	13,900	13,500	13,225		
5.0	12,880	12,880	12,880	12,750	12,475	12,325		
6.0	9,635	9,640	9,640	9,645	9,645	9,645	9,650	9,295
7.0	7,325	7,330	7,330	7,335	7,335	7,335	7,340	7,340
8.0		5,795	5,795	5,800	5,800	5,800	5,805	5,805
9.0		4,700	4,700	4,705	4,705	4,705	4,710	4,710
10.0			3,885	3,890	3,890	3,890	3,895	3,895
12.0				2,745	2,745	2,745	2,750	2,750
14.0					1,985	1,985	1,990	1,990
16.0						1,445	1,450	1,450
18.0							1,045	1,045
20.0								730

A6-829-013176



**85%**

m	8.6	10.4	12.2	14.0	15.8	17.7	19.5	21.3
3.0	22,500	16,325	16,325					
3.5	18,140	16,325	16,325	15,875				
4.0	15,920	15,625	15,575	15,250				
4.5	14,285	14,250	14,200	13,900	13,500	13,225		
5.0	12,880	12,880	12,880	12,750	12,475	12,325		
6.0	10,450	10,450	10,450	10,425	10,200	9,995	9,780	9,295
7.0	7,995	7,995	7,995	7,995	7,995	7,995	7,880	7,745
8.0		6,360	6,360	6,360	6,360	6,360	6,360	6,360
9.0		5,200	5,200	5,200	5,200	5,200	5,200	5,200
10.0			4,335	4,335	4,335	4,335	4,335	4,335
12.0				3,120	3,120	3,120	3,120	3,120
14.0					2,315	2,315	2,315	2,315
16.0						1,740	1,740	1,740
18.0							1,310	1,310
20.0								975

A6-829-013169

**Lifting capacities for telescopic boom**  
**Traglasten am Teleskopausleger**  
**Capacités de levage à la flèche télescopique**  
**Capacidades de elevación con pluma telescópico**



8.6 – 21.3 m



0%



360°



4,610 kg



**BS/DIN**

m	8.6	10.4	12.2	14.0	15.8	17.7	19.5	21.3
3.0	13,375	13,375	13,375					
3.5	10,225	10,225	10,225	10,225				
4.0	8,185	8,185	8,185	8,185				
4.5	6,745	6,745	6,745	6,745	6,745	6,745		
5.0	5,675	5,675	5,675	5,675	5,675	5,675		
6.0	4,200	4,200	4,200	4,200	4,200	4,200	4,200	4,200
7.0	3,230	3,230	3,230	3,230	3,230	3,230	3,230	3,230
8.0		2,515	2,515	2,520	2,520	2,520	2,525	2,525
9.0		1,965	1,965	1,970	1,970	1,970	1,975	1,975
10.0			1,540	1,545	1,545	1,545	1,550	1,550
12.0				935	935	935	940	940
14.0					510	510	515	515

A6-829-012100A



**75%**

m	8.6	10.4	12.2	14.0	15.8	17.7	19.5	21.3
3.0	13,375	13,375	13,375					
3.5	10,225	10,225	10,225	10,225				
4.0	8,185	8,185	8,185	8,185				
4.5	6,745	6,745	6,745	6,745	6,745	6,745		
5.0	5,675	5,675	5,675	5,675	5,675	5,675		
6.0	4,200	4,200	4,200	4,200	4,200	4,200	4,200	4,200
7.0	3,230	3,230	3,230	3,230	3,230	3,230	3,230	3,230
8.0		2,540	2,540	2,540	2,540	2,540	2,540	2,540
9.0		2,025	2,025	2,025	2,025	2,025	2,025	2,025
10.0			1,630	1,630	1,630	1,630	1,630	1,630
12.0				1,055	1,055	1,055	1,055	1,055
14.0					655	655	655	655

A6-829-013171

**Lifting capacities for telescopic boom**  
**Traglasten am Teleskopausleger**  
**Capacités de levage à la flèche télescopique**  
**Capacidades de elevación con pluma telescópica**



8.6 – 21.3 m



20.5 x 25



360°/0°



4,610 kg



**BS/DIN**

m	0 kph				< 4 kph			
	8.6	10.4	12.2	14.0	8.6	10.4	12.2	14.0
360°					0°			
3.0	11,875	11,875			15,325			
3.5	9,910	9,910	7,250		13,650			
4.0	7,845	7,845	7,250		12,125			
4.5	6,380	6,380	6,380	6,380	10,875	10,875	10,875	10,875
5.0	5,280	5,280	5,280	5,280	9,810	9,810	9,810	9,810
6.0	3,750	3,750	3,750	3,750	7,245	7,245	7,245	7,245
7.0	2,735	2,735	2,735	2,735	5,425	5,425	5,425	5,425
8.0		2,050	2,050	2,050		3,850	3,850	3,850
9.0		1,605	1,605	1,605		3,325	3,325	3,325
10.0			1,265	1,265			2,870	2,870
12.0				,765				2,035

A6-829-013577

A6-829-013578



**85%**

m	0 kph							< 4 kph							
	8.6	10.4	12.2	14.0	15.8	17.7	19.5	8.6	10.4	12.2	14.0	15.8	17.7	19.5	21.3
360°								0°							
3.0	11,875	11,875						15,325							
3.5	10,175	10,175	7,250					13,650							
4.0	8,545	8,545	7,250					12,125							
4.5	6,985	6,985	6,985	6,985				10,875	10,875	10,875	10,875				
5.0	5,820	5,820	5,820	5,820				9,810	9,810	9,810	9,810				
6.0	4,190	4,190	4,190	4,190	4,190	3,350		7,900	7,900	7,900	7,900	5,530	5,530		
7.0	3,105	3,105	3,105	3,105	3,105	2,445	2,445	5,965	5,965	5,965	5,965	4,745	4,745	4,260	
8.0		2,380	2,380	2,380	2,380	2,380	2,245		3,850	3,850	3,850	3,850	3,850	3,850	
9.0		1,910	1,910	1,910	1,910	1,910	1,820		3,325	3,325	3,325	3,325	3,325	3,260	3,175
10.0			1,540	1,540	1,540	1,540	1,540			2,890	2,890	2,890	2,890	2,780	2,780
12.0				1,010	1,010	1,010	1,010				2,220	2,220	2,220	2,220	2,095
14.0					645	645	645					1,720	1,720	1,720	1,700
16.0													1,315	1,315	1,315
18.0														985	985
20.0															725

A6-829-009061

A6-829-009062

m	0 kph							
	8.6	10.4	12.2	14.0	15.8	17.7	19.5	21.3
0° (±6°)								
3.0	12,975	11,875						
3.5	11,700	10,175	9,525					
4.0	10,550	9,800	8,620					
4.5	9,610	9,610	7,605	7,480				
5.0	8,825	8,825	6,810	6,810				
6.0	7,585	7,585	5,625	5,625	5,530	5,530		
7.0	5,965	5,965	4,745	4,745	4,745	4,745	4,260	4,260
8.0		4,700	4,700	3,965	3,965	3,965	3,965	3,965
9.0		3,875	3,875	3,875	3,260	3,260	3,260	3,260
10.0			3,250	3,250	3,250	2,780	2,780	2,780
12.0				2,355	2,355	2,355	2,095	2,095
14.0					1,750	1,750	1,750	1,700
16.0						1,315	1,315	1,315
18.0							985	985
20.0								725

A6-829-009060

0° = over front, über Vorderkante, sur avant, por la parte frontal

**Lifting capacities for telescopic swingaway**  
**Traglasten Teleskopklappspitze**  
**Capacités de levage à l'extension télescopique**  
**Capacidades de elevación para plumín telescópico**



21.3 m



7.6 – 13.1 m



100%



360°



4,610 kg



**BS/DIN**

m	21.3								
	7.6			10.4			13.1		
	0°	15°	30°	0°	15°	30°	0°	15°	30°
6.0	5,670								
8.0	5,580	3,310		3,490			2,040		
10.0	4,430	3,075	2,380	2,985	2,220		1,880		
12.0	3,810	2,695	2,160	2,480	1,995	1,450	1,655	1,270	
14.0	3,265	2,450	1,995	2,180	1,800	1,290	1,505	1,185	995
16.0	2,880	2,315	1,905	1,950	1,615	1,115	1,365	1,115	960
18.0	2,230	2,230	1,815	1,710	1,425	1,020	1,250	1,040	920
20.0	1,730	1,730	1,725	1,560	1,270	930	1,145	980	880
22.0	1,335	1,335	1,330	1,475	1,150	865	1,035	945	840
24.0	1,015	1,015	1,010	1,245	1,095	835	975	900	790
26.0	750	750		970	965	815	950	880	755
28.0				745	740		885	855	725
30.0				550	545		705	705	690
32.0							550	550	

A6-829-00886A



**85%**

m	21.3								
	7.6			10.4			13.1		
	0°	15°	30°	0°	15°	30°	0°	15°	30°
6.0	5,670								
8.0	5,580	3,310		3,490			2,040		
10.0	4,430	3,075	2,380	2,985	2,220		1,880		
12.0	3,810	2,695	2,160	2,480	1,995	1,450	1,655	1,270	
14.0	3,265	2,450	1,995	2,180	1,800	1,290	1,505	1,185	995
16.0	2,970	2,315	1,905	1,950	1,615	1,115	1,365	1,115	960
18.0	2,585	2,255	1,815	1,710	1,425	1,020	1,250	1,040	920
20.0	2,055	2,055	1,760	1,560	1,270	930	1,145	980	880
22.0	1,635	1,635	1,635	1,475	1,150	865	1,035	945	840
24.0	1,295	1,295	1,295	1,405	1,095	835	975	900	790
26.0	1,015	1,015		1,230	1,070	815	950	880	755
28.0				985	985		925	855	725
30.0				780	780		895	820	690
32.0							770	770	

A6-829-008683

**Lifting capacities for telescopic swingaway**  
**Traglasten Teleskopklappspitze**  
**Capacités de levage à l'extension télescopique**  
**Capacidades de elevación para plúmín telescópico**



21.3 m



7.6 – 13.1 m



50%



360°



4,610 kg



**BS/DIN**

m	21.3								
	7.6			10.4			13.1		
	0°	15°	30°	0°	15°	30°	0°	15°	30°
6.0	5,670								
8.0	5,580	3,310		3,490			2,040		
10.0	4,305	3,075	2,380	2,985	2,220		1,880		
12.0	3,040	2,695	2,160	2,480	1,995	1,450	1,655	1,270	
14.0	2,185	2,185	1,995	2,180	1,800	1,290	1,505	1,185	995
16.0	1,580	1,580	1,575	1,840	1,615	1,115	1,365	1,115	960
18.0	1,125	1,125	1,120	1,370	1,370	1,020	1,250	1,040	920
20.0	775	775	770	1,010	1,005	930	1,060	980	880
22.0				720	715	710	800	800	795
24.0							580	580	575

A6-829-013178











**85%**



m	21.3								
	7.6			10.4			13.1		
	0°	15°	30°	0°	15°	30°	0°	15°	30°
6.0	5,670								
8.0	5,580	3,310		3,490			2,040		
10.0	4,305	3,075	2,380	2,985	2,220		1,880		
12.0	3,220	2,695	2,160	2,480	1,995	1,450	1,655	1,270	
14.0	2,455	2,450	1,995	2,180	1,800	1,290	1,505	1,185	995
16.0	1,890	1,890	1,890	1,950	1,615	1,115	1,365	1,115	960
18.0	1,415	1,415	1,415	1,600	1,425	1,020	1,250	1,040	920
20.0	1,040	1,040	1,040	1,255	1,255	930	1,145	980	880
22.0	740	740	740	960	960	865	1,035	945	840
24.0				705	705	705	805	805	790
26.0							615	615	615

A6-829-013174



**Lifting capacities for fixed length non-offsettable swingaway**  
**Traglasten für Festlängen nicht abwinkelbare Klappspitze**  
**Capacités de levage sur extension treillis fixe non télescopique**  
**Capacidades de elevación para plumín no telescópico, no angulable**

	21.3 m		7.6 m		100%/50%		360°		4,610 kg
		<b>BS/DIN</b>	100%						
m	<b>21.3</b>								
m	<b>7.6</b>								
6.0	5,670								
8.0	5,580								
10.0	4,430								
12.0	3,810								
14.0	3,265								
16.0	2,970								
18.0	2,500								
20.0	2,000								
22.0	1,605								
24.0	1,285								
26.0	1,020								



A6-829-008885A

		<b>BS/DIN</b>	50%						
m	<b>21.3</b>								
m	<b>7.6</b>								
6.0	5,670								
8.0	5,580								
10.0	4,430								
12.0	3,300								
14.0	2,450								
16.0	1,840								
18.0	1,385								
20.0	1,035								
22.0	750								
24.0	520								

A6-829-013177

		<b>85%</b>	100%						
m	<b>21.3</b>								
m	<b>7.6</b>								
6.0	5,670								
8.0	5,580								
10.0	4,430								
12.0	3,810								
14.0	3,265								
16.0	2,970								
18.0	2,835								
20.0	2,305								
22.0	1,885								
24.0	1,545								
26.0	1,265								

A6-829-008679

		<b>85%</b>	50%						
m	<b>21.3</b>								
m	<b>7.6</b>								
6.0	5,670								
8.0	5,580								
10.0	4,430								
12.0	3,605								
14.0	2,780								
16.0	2,135								
18.0	1,655								
20.0	1,280								
22.0	980								
24.0	735								
26.0	530								

A6-829-013172

**Working range**  
**Arbeitsbereiche**  
**Portée flèche**  
**Gama de trabajo**



8.6 – 21.3 m



7.0 m



360°

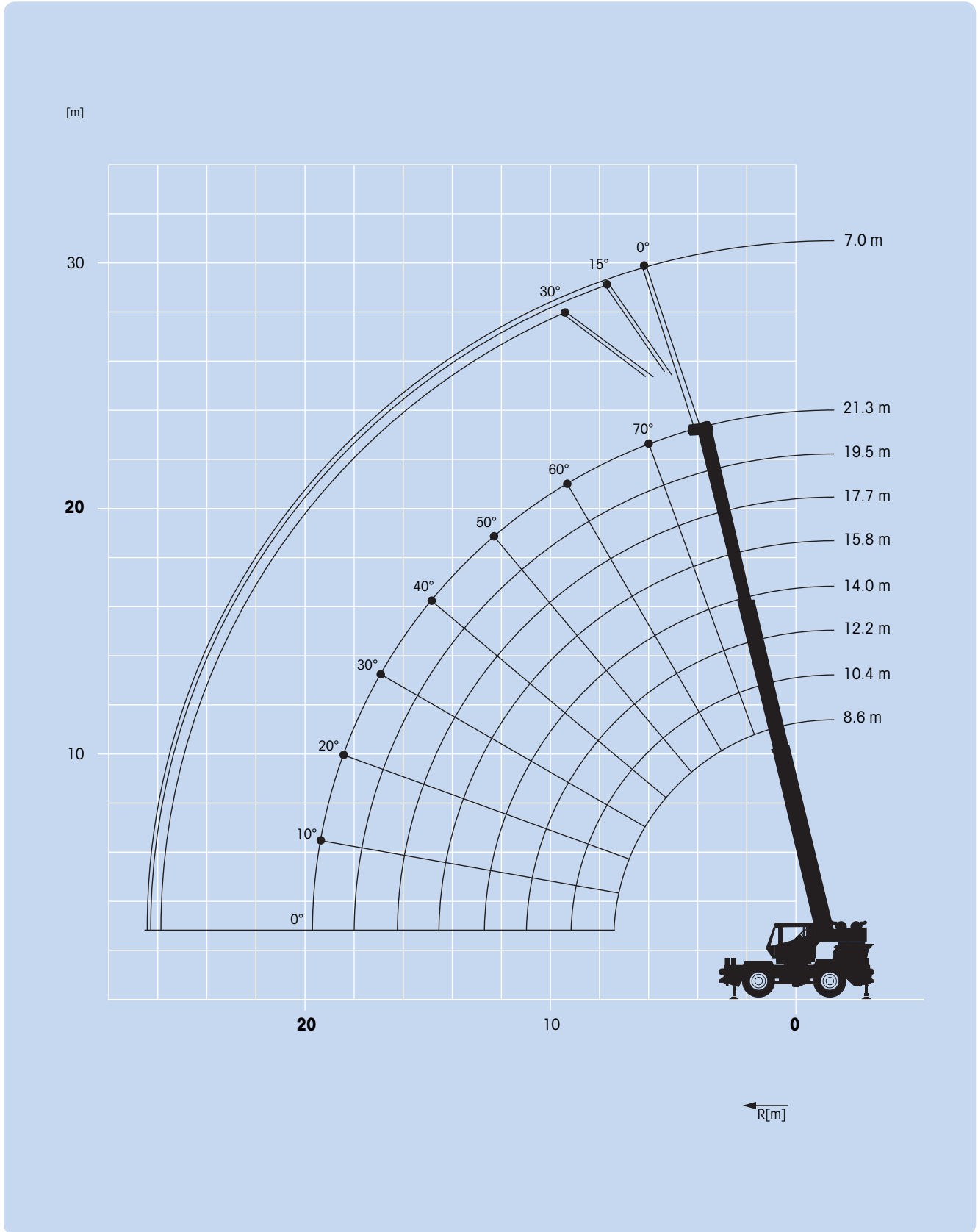

**Lifting capacities for telescopic A-frame jib**  
**Traglasten Teleskopklappspitze**  
**Capacités de levage à l'extension télescopique**  
**Capacidades de elevación para plumín telescópico**



21.3 m



7.0 m



100%/50%



360°



4,610 kg



**BS/DIN**

100%



	21.3		
	7.0		
	0°	15°	30°
<b>75°</b>	5,440 (8.2)	3,490 (9.9)	2,300 (10.9)
<b>70°</b>	4,715 (10.2)	3,175 (11.6)	2,175 (12.5)
<b>65°</b>	3,855 (12.3)	2,855 (13.7)	2,040 (14.6)
<b>60°</b>	3,355 (14.3)	2,470 (15.6)	1,950 (16.5)
<b>55°</b>	2,990 (16.2)	2,265 (17.5)	1,855 (18.2)
<b>50°</b>	2,455 (18.0)	2,130 (19.2)	1,765 (19.8)
<b>45°</b>	2,025 (19.7)	1,800 (20.7)	1,685 (21.3)
<b>40°</b>	1,705 (21.2)	1,530 (22.1)	1,450 (22.6)
<b>35°</b>	1,465 (22.6)	1,330 (23.3)	1,265 (23.7)
<b>30°</b>	1,275 (23.7)	1,170 (24.4)	

( ) = Ref Rad.

A6-829-00882A



**85%**

100%



	21.3		
	7.0		
	0°	15°	30°
<b>75°</b>	5,440 (8.2)	3,490 (9.9)	2,300 (10.9)
<b>70°</b>	4,715 (10.2)	3,175 (11.6)	2,175 (12.5)
<b>65°</b>	3,855 (12.3)	2,855 (13.7)	2,040 (14.6)
<b>60°</b>	3,355 (14.3)	2,470 (15.6)	1,950 (16.5)
<b>55°</b>	2,990 (16.2)	2,265 (17.5)	1,855 (18.2)
<b>50°</b>	2,765 (18.0)	2,130 (19.2)	1,765 (19.8)
<b>45°</b>	2,340 (19.7)	2,040 (20.7)	1,720 (21.3)
<b>40°</b>	2,000 (21.2)	1,820 (22.1)	1,675 (22.6)
<b>35°</b>	1,740 (22.6)	1,605 (23.3)	1,540 (23.7)
<b>30°</b>	1,545 (23.7)	1,435 (24.4)	

( ) = Ref Rad.

A6-829-008662



**85%**

50%



	21.3		
	7.0		
	0°	15°	30°
<b>75°</b>	5,440 (8.2)	3,490 (9.9)	2,300 (10.9)
<b>70°</b>	4,555 (10.2)	3,175 (11.6)	2,175 (12.5)
<b>65°</b>	3,435 (12.3)	2,855 (13.7)	2,040 (14.6)
<b>60°</b>	2,650 (14.3)	2,245 (15.6)	1,950 (16.5)
<b>55°</b>	2,090 (16.2)	1,790 (17.5)	1,630 (18.2)
<b>50°</b>	1,665 (18.0)	1,455 (19.2)	1,335 (19.8)
<b>45°</b>	1,360 (19.7)	1,200 (20.7)	1,115 (21.3)
<b>40°</b>	1,125 (21.2)	1,005 (22.1)	945 (22.6)
<b>35°</b>	950 (22.6)	855 (23.3)	810 (23.7)
<b>30°</b>	815 (23.7)	740 (24.4)	

( ) = Ref Rad.

A6-829-015504

**Weight reduction for load handling devices**  
**Gewichte der Lastaufnahmemittel**  
**Réductions de charge pour accessoires de levage**  
**Deducciones de peso par accesorios de elevación**

<b>Auxiliary boom nose</b> / Zusatz-Auslegerkopf / <i>Tête de flèche auxiliaire</i> / Cabeza auxiliar	51 kg
<b>Hookblocks</b> / Hakenflaschen / <i>Moufles</i> / Ganchos	
<b>25 tonne 4 sheave</b> / Seilscheiben / <i>reas</i> / <i>poleas</i>	272 kg
<b>10.9 tonne 1 sheave</b> / Seilscheiben / <i>reas</i> / <i>poleas</i>	163 kg
<b>4.5 tonne hook and weight</b> / Einseilhaken / <i>crochet lesté</i> / gancho y bola	78 kg
<b>7.0 m Stowaway jib</b> / Hilfsausleger / <i>Fléchette à repliage latéral</i> / <i>Extension plegable</i>	
<b>Stowed</b> / Seitlich angeklappt / <i>En position de transport</i> / <i>plegada</i>	173 kg
<b>Erected</b> / Arbeitsstellung / <i>En position de travail</i> / <i>montada</i>	885 kg
<b>7.6 m Extension</b> / Klappspitze / <i>Prolongacion</i>	
<b>Stowed</b> / Seitlich angeklappt / <i>En position de transport</i> / <i>In posicion de transporte</i>	183 kg
<b>Erected</b> / In Arbeitsstellung / <i>En position de travail</i> / <i>Montada</i>	581 kg
<b>7.6 m – 13.1 m Extension</b> / Klappspitze / <i>Prolongacion</i>	
<b>Stowed</b> / Seitlich angeklappt / <i>En position de transport</i> / <i>plegada</i>	329 kg
<b>Erected (retracted)</b> / Arbeitsstellung (einsteleskopiert) / <i>En position de travail (rentré)</i> / <i>montada (recogido)</i>	1,520 kg
<b>Erected (extended)</b> / Arbeitsstellung (austeleskopiert) / <i>En position de travail (deployé)</i> / <i>montada (extendido)</i>	1,954 kg

**NOTE:**

All load handling devices and boom attachments are considered part of the load and suitable allowances must be made for their combined weights.

**HINWEIS:**

Alle Lastaufnahmemittel und jede Zusatzausrüstung des Hauptauslegers werden als Teil der Traglast betrachtet und ihre kombinierten Gewichte müssen beim Feststellen der Nettolast entsprechend berücksichtigt (abgezogen) werden.

**REMARQUE:**

Les équipements complémentaires et accessoires de levage sont considérés comme faisant partie de la charge; les réductions de charges de leurs poids combinés doivent être effectuées.

**NOTA:**

Todos los aparos de elevacion e implementos de pluma son considerados parte de la carga y deben ser tenidos en cuenta para calcular los pesos a elevar.

**Symbols Glossary**  
**Symbolerklärungs**  
**Glossaire des symboles**  
**Glosario de símbolos**

**Notes**  
**Hinweise**  
**Notes**  
**Notas**

	Axle load Achslast Charge à l'essieu Carga por eje		Auxiliary hoist Hilfshubwerk Treuil auxiliaire Cabrestante auxiliar
	Boom Ausleger Flèche Pluma		Hookblock Hakenflasche Moufle Gancho
	Boom elevation Wippwerk Relevage Elevacion de pluma		Jib Spitze Flèche Plumín
	Boom telescoping Teleskopieren Télescopage de flèche Telescopaje de pluma		Lattice extension Gitterspitze Extension treillis Extensión de celosía
	Counterweight Gegengewicht Contrepoids Contrapeso		Outriggers Abstützung Calage Estabilizadores
	Crane functions Kranbewegungen Mouvements de la grue Funciones de la grúa		Radius Ausladung Portée Radio
	Crane travel Fahrstellung Déplacement de la grue Grúa en traslado		Slewing/Working range Drehwerk/Arbeitsbereich Orientation/Rayon d'operation Giro/Gamma de trabajo
	Free on wheels Freistehend Sur pneus Sobre neumáticos		Travel speed Fahrgeschwindigkeit Vitesse de déplacement Velocidad de desplazamiento
	Gear Gang Rapport Cambio		Speed Geschwindigkeit Vitesse Velocidad
	Gradeability Steigfähigkeit Aptitude en pente Superacion de pendientes		Low range Kleinste Übersetzung Gamme basse Marchas cortas
	Main hoist Haupthubwerk Treuil principal Cabrestante principal		Tyres Bereifung Pneumatiques Neumáticos

A large grid area for taking notes, consisting of a blue border and a light blue grid pattern.

**Notes**

**Hinweise**

**Notes**

**Notas**

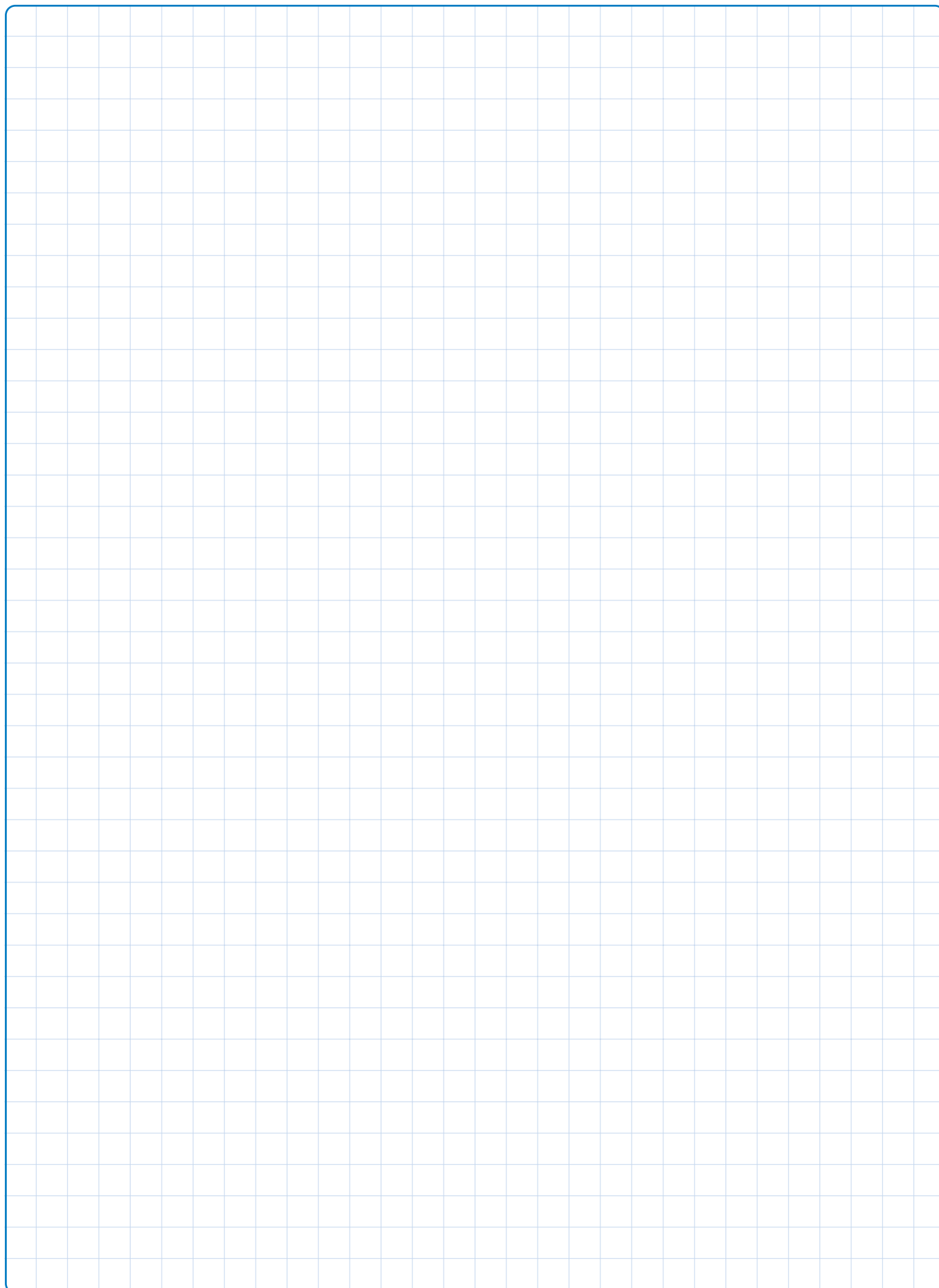

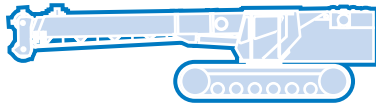
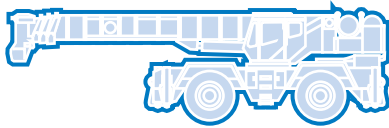
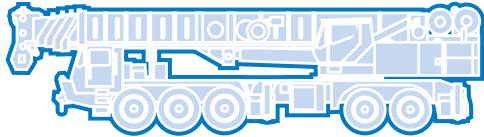
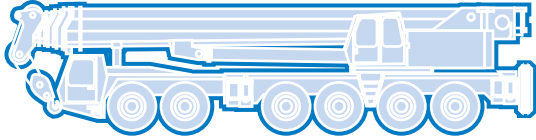
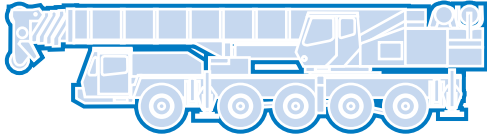

**Grove Worldwide – World Headquarters**

**Grove North America**  
1565 Buchanan Trail East  
P.O. Box 21  
Shady Grove, Pennsylvania 17256, U.S.A.  
Tel: [Int + 1] (717) 597-8121  
Fax: [Int + 1] (717) 597-4062  
Western Hemisphere, Asia/Pacific

**Grove Europe Limited\***  
Sunderland SR4 6TT, England  
Tel: [Int + 44] 191 565-6281  
Fax: [Int + 44] 191 564-0442  
Europe, Africa, Middle East

**Grove Europe Limited\***  
P.O. Box No. 268  
4A Kimber Road  
Abingdon, Oxfordshire, OX141SG  
Tel: [Int + 44] 1235 55-3184  
Fax: [Int + 44] 1235 55-3218  
\*Grove Europe Limited, Registered in England,  
Number 1845128, Registered office, Crown Works,  
Pallion, Sunderland, Tyne & Wear, England SR4 6TT

**Deutsche Grove GmbH**  
**Sales and Service**  
Helmholtzstrasse 12, Postfach 5026  
D-40750 Langenfeld, Germany  
Tel: [Int + 49] (2173) 8909-0  
Fax: [Int + 49] (2173) 8909-30

**Wilhelmshaven Works**  
Industriegelände West, Postfach 1853  
D-26358 Wilhelmshaven, Germany  
Tel: [Int + 49] (4421) 294-0  
Fax: [Int + 49] (4421) 294-301

**Grove France S.A.**

16, chaussée Jules-César, 95520 OSNY  
B.P. 203, 95523 CERGY PONTOISE CEDEX  
France  
Tel: [Int + 33] (1) 30313150  
Int: [Int + 33] (1) 30386085

**Grove Asia/Pacific - Regional Office**

171 Chin Swee Road  
#06-01 San Centre  
Singapore 0316  
Tel: [Int + 65] 536-6112  
Fax: [Int + 65] 536-6119  
Asia/Pacific, Near East

**Grove China - Representative Office**

Beijing Suite  
No. 33 East Chang An Avenue  
Beijing, 100004, China  
Tel: [Int + 86] (10) 513-7766  
Fax: [Int + 86] (10) 513-7307

**Grove Product Support**

Western Hemisphere, Asia/Pacific  
1086 Wayne Avenue  
Chambersburg, Pennsylvania USA  
Tel: [Int + 1] (717) 263-5100  
Fax: [Int + 1] (717) 267-0404

Europe, Africa, Middle East  
Sunderland SR4 6TT, England  
Tel: [Int + 44] 191 565-6281  
Parts Fax: [Int + 44] 191 510-9242  
Service Fax: [Int + 44] 191 510-9560

<http://www.groveworldwide.com>

Constant improvement and engineering progress make it necessary that we reserve the right to make specification, equipment, and price changes without notice. Illustrations shown may include optional equipment and accessories and may not include all standard equipment.

Wir verbessern unsere Produkte ständig und integrieren den technischen Fortschritt. Aus diesem Grund behalten wir uns das Recht vor, die technischen Daten, die Ausstattungsdetails und die Preise unserer Maschinen ohne Vorankündigung zu ändern.

Du fait de sa politique d'amélioration constante de ses produits liée au progrès technique, la Société se réserve le droit de procéder sans préavis à des changements de spécifications, d'équipement ou de prix. Les illustrations peuvent comporter des équipements ou accessoires optionnels ou ne pas comporter des équipements standards.

El perfeccionamiento constante y el avance tecnológico hacen necesario que la empresa se reserve el derecho de efectuar cambios en las especificaciones, equipo y precios sin previo aviso. En las ilustraciones se puede incluir equipo y accesorios opcionales y es posible que no se muestre el equipo normal.

**Distributed By:**